

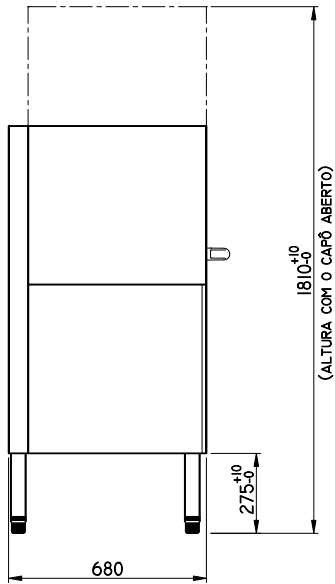

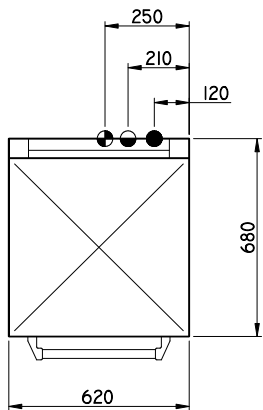

VISTA FRONTAL



VISTA LATERAL



VISTA SUPERIOR

-  - SAÍDA DA MANGUEIRA DE ÁGUA.
-  - SAÍDA DA MANGUEIRA DE ESGOTO.
-  - SAÍDA DO CABO ELÉTRICO.

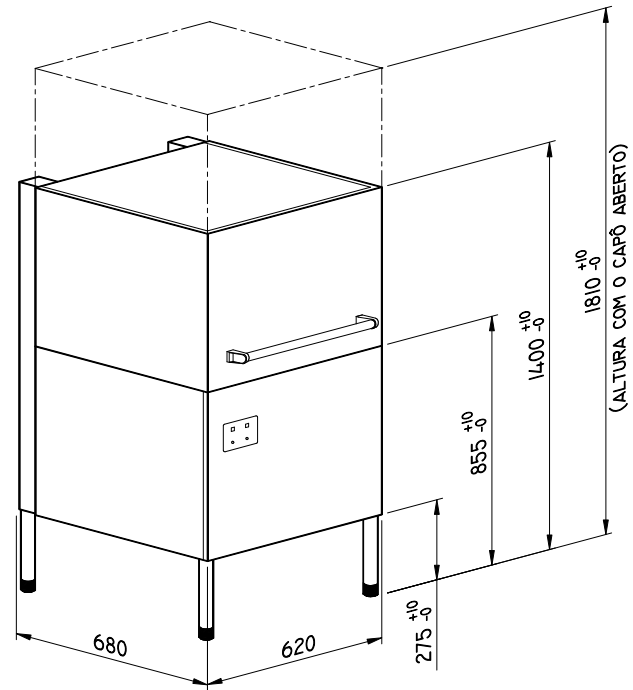

DIMENSÕES EM MILÍMETROS

 a marca da ecoeficiência	DESCRIÇÃO: DESENHO DIMENSIONAL		
	EQUIPAMENTO: NT 500		
DES.: LUCIANO	ESCALA: S/E	DATA: 26/01/09	REV.: S/REV

LIMITE IDEAL PARA  
POSICIONAMENTO DOS PONTOS  
ELÉTRICO / ÁGUA

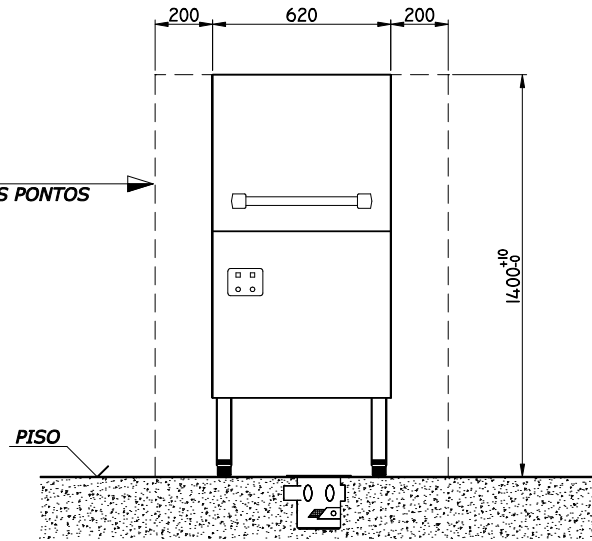

VISTA FRONTAL

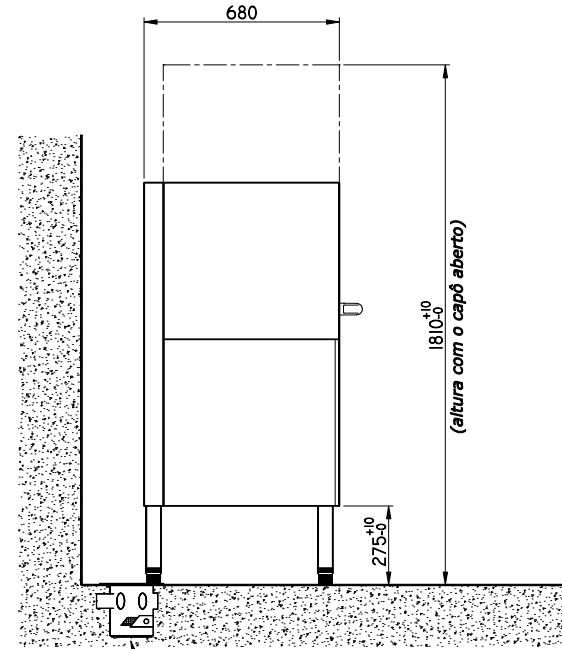

CAIXA SIFONADA Ø150 mm

VISTA LATERAL

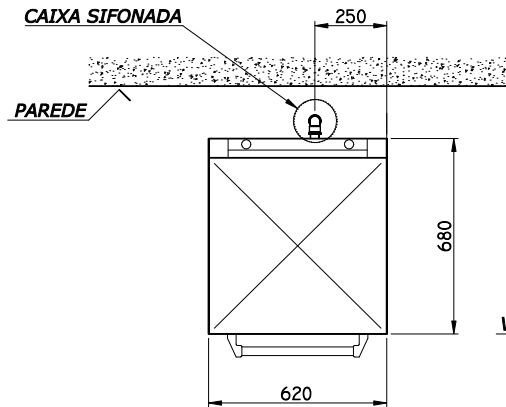

VISTA SUPERIOR

**NOTAS:**

- ESGOTO: CAIXA SIFONADA Ø150 mm, POSICIONADA OBRIGATORIAMENTE NO NÍVEL DO PISO, CONFORME DESENHO ACIMA.

- ESPECIFICAÇÕES DOS PONTOS DE INSTALAÇÃO CONFORME MANUAL E/OU DESCRITIVO TÉCNICO.

DIMENSÕES EM MILÍMETROS

	DESCRIÇÃO: INSTALAÇÃO SOBRE O PISO		
	EQUIPAMENTO: NT 500		
DES.: LUCIANO	ESCALA: S/E	DATA: 11/06/13	REV.: B

**MONTAGEM EM "L" (DE CANTO) - LADO ESQUERDO**

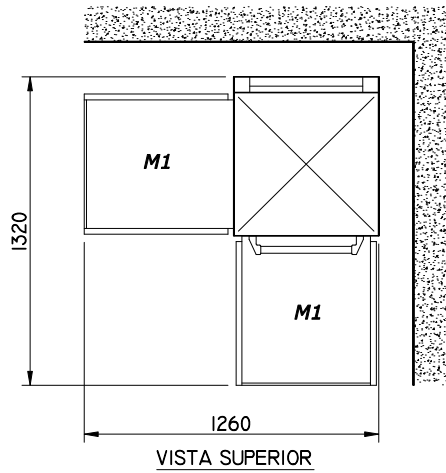

**MONTAGEM EM "L" (DE CANTO) - LADO DIREITO**

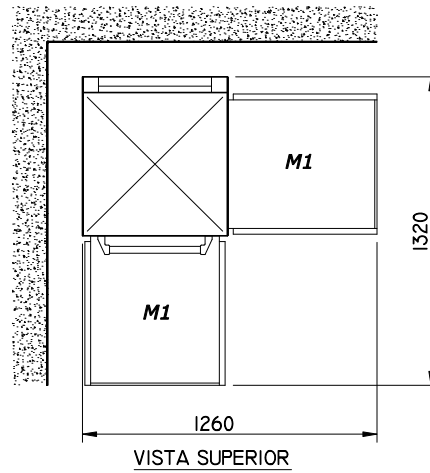

**MONTAGEM EM LINHA**

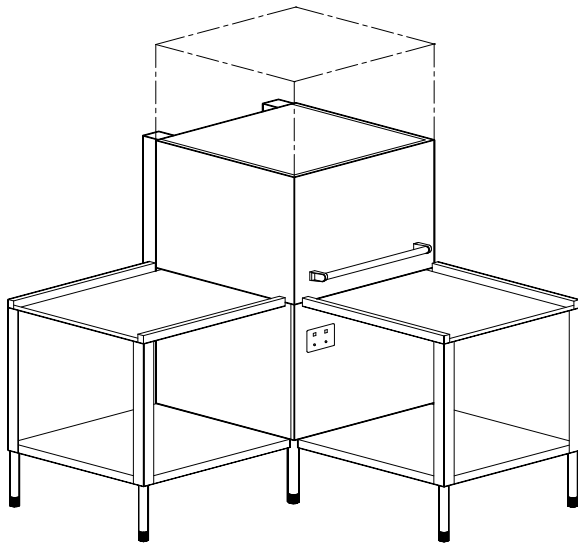
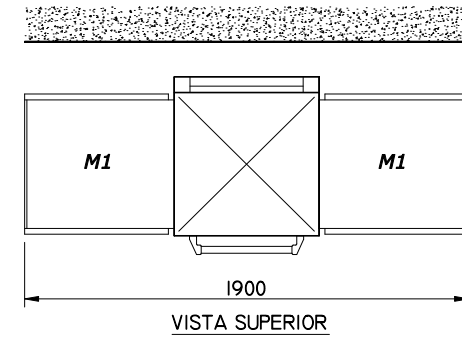

FURAÇÃO TECLADO PADRÃO

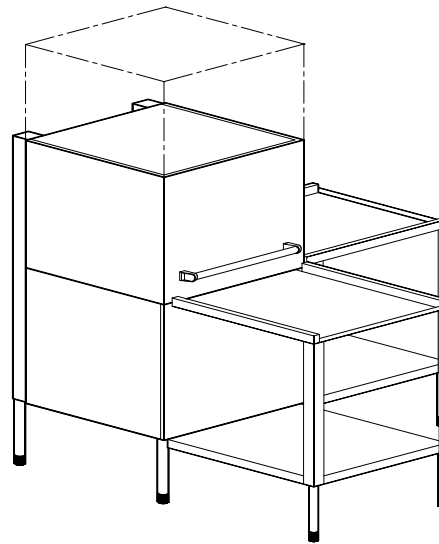

FURAÇÃO TECLADO INVERTIDA

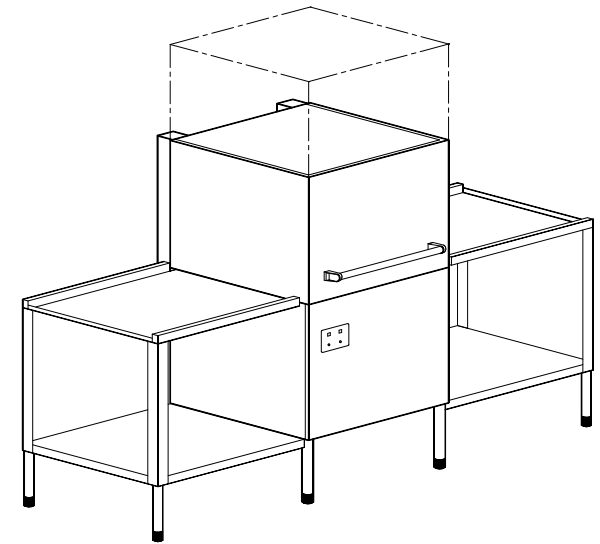

FURAÇÃO TECLADO PADRÃO

DIMENSÕES EM MILÍMETROS

	DESCRIÇÃO: MONTAGEM DAS MESAS		
	EQUIPAMENTO: NT 500		
DES.: LUCIANO	ESCALA: S/E	DATA: 26/01/09	REV.: S/REV